

Assembly Instructions

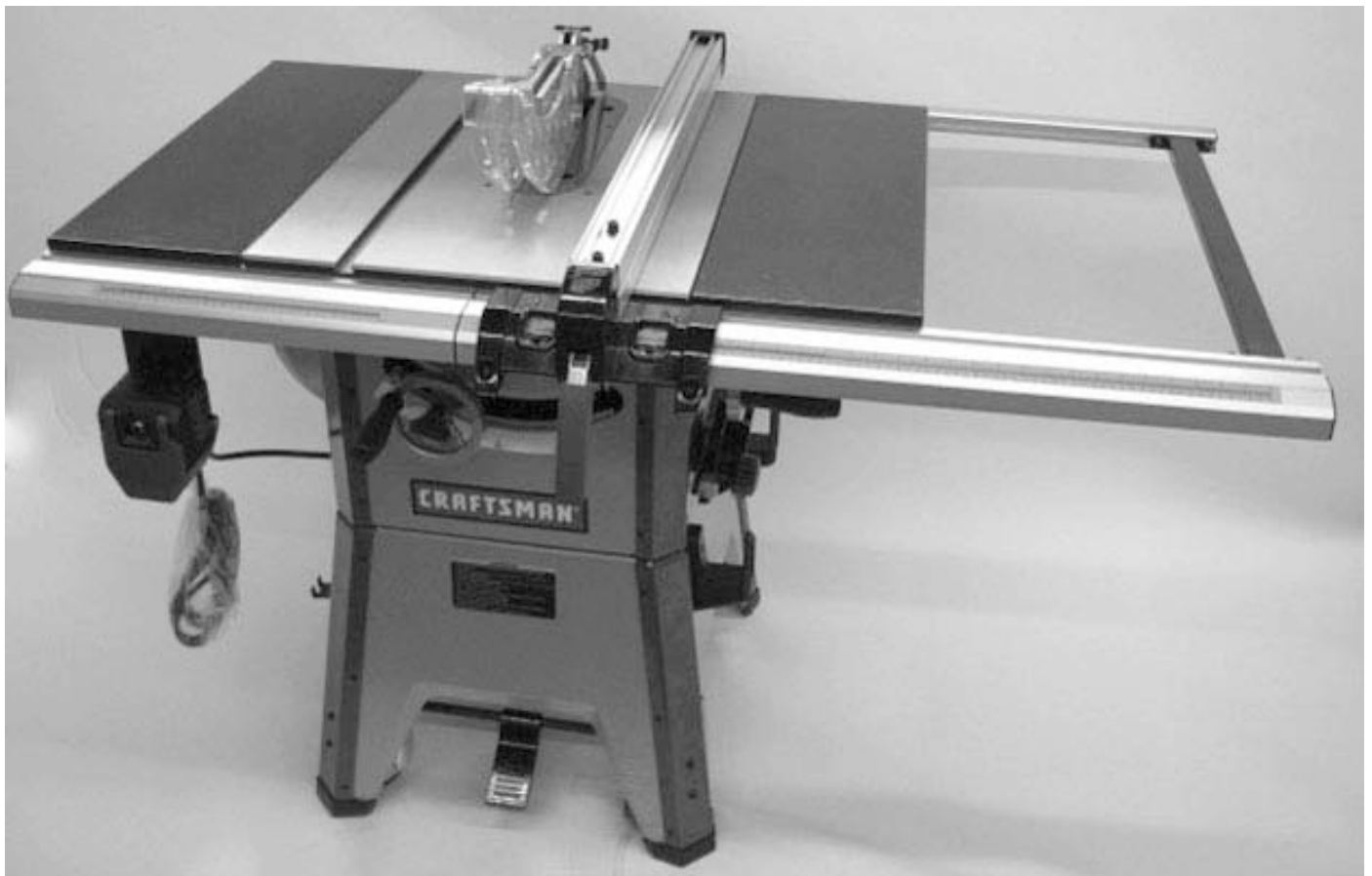

10" CONTRACTOR TABLE SAW

Model No.
351.218330



Sears Brands Management Corporation, Hoffman Estates, IL 60179 U.S.A.

www.sears.com/craftsman

31624.00 Draft (10/08/09)

UNPACKING

The table saw body comes assembled as one unit. Additional parts which need to be fastened to the saw should be located and accounted for before assembling:

- A Extension Table (2)
- B Dust Chute
- C Front Rail (2)
- D Rear Rail (2)
- E Miter Gauge Assembly
- F Blade Guard Assembly
- G Dado Insert
- H Table Insert
- I Handwheel Assembly with Knob (2)
- J Rip Fence Assembly
- K Rubber Foot (4)
- L Anti-kickback Pawl Assembly
- M Line Cord Hooks (2)
- N Brace
- O Rip Fence Storage Hooks (2)
- P Blade Guard Storage Hooks (2)
- Q Push Stick Storage Hooks (2)
- R Push Stick
- S Base Panel (4)
- T Corner Support (4)
- U Caster Set (2)

Hardware Bag #1

- M10 x 25 Socket Head Bolt (6)
- M10 Lock Washer (6)
- M10 Flat Washer (6)

Hardware Bag #2

- M8 x 28 Hex Head Bolt (8)
- M8 x 25 Hex Head Bolt (8)
- M8 x 20 Hex Head Bolt (4)
- M8 Lock Washer (20)
- M8 Flat Washer (20)
- M8 Hex Nut (16)
- M8 Acorn Hex Nut (4)

Hardware Bag #3

- M6 x 16 Hex Head Screw (2)
- M6 Flat Washer (2)
- M6 Hex Nut (2)
- M6 Lock Washer (2)

Hardware Bag #4

- M10 x 25 Socket Head Bolt (4)
- M8 x 16 Socket Pan Head Screw (8)
- M6 x 12 Socket Pan Head Screw (24)
- M6 x 16 Socket Head Bolt (2)
- M5 x 12 Socket Head Bolt (4)
- M3 x 10 Pan Head Screw (4)
- M10 Lock Washer (4)
- M6 Hex Nut (2)
- M5 Lock Washer (4)
- M3 Lock Washer (4)
- M10 Flat Washer (4)
- M6 Flat Washer (2)
- M5 Flat Washer (4)
- M3 Flat Washer (4)

© Sears, Roebuck and Co.

- Hardware Bag #5
- 10/13mm Open End Wrench
- 4mm Hex Wrench
- 5mm Hex Wrench
- 8mm Hex Wrench

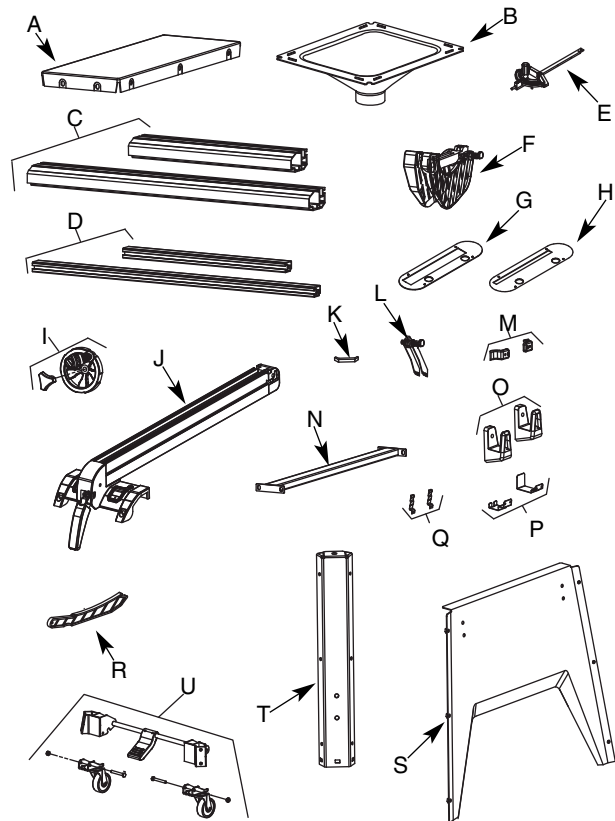

Figure 1 - Unpacking

STEP 1

INSTALL HANDWHEELS

- Remove saw cabinet and place upside down on cardboard box or cardboard on floor.
- Place one of the handwheels onto the blade raise/lower shaft located on the front of the cabinet. Align the groove in the back of the handwheel with the pin.
- Thread the locking knob onto the threaded end of the shaft.
- Repeat the steps above to assemble the remaining handwheel and locking knob onto the blade tilt shaft located on the side of the cabinet.

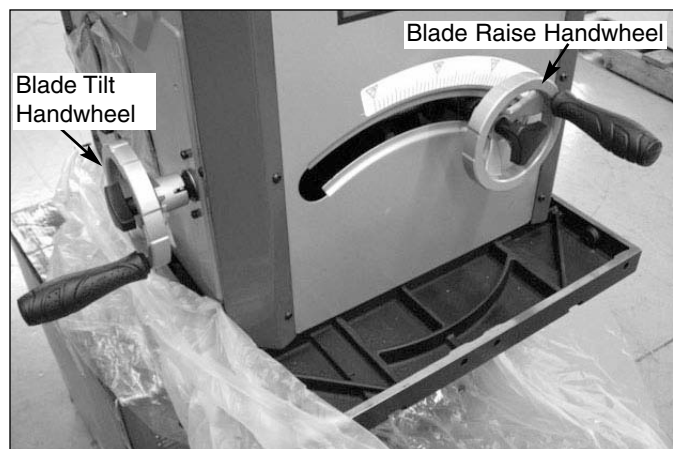

Figure 2

STEP 2

- Use the blade tilt handwheel to tilt the blade completely to 45°.
- Remove the packing material from behind the motor.
- Return blade to the 0° position.

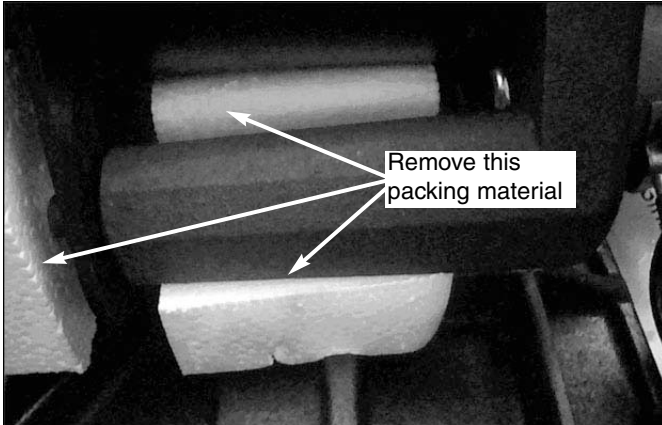

Figure 3

STEP 3

ASSEMBLE MOBILE BASE PANELS

Tools Required: 4mm Hex Wrench

Hardware Required: Twenty-four M6 x 12 socket pan head bolts (Hardware bag #4).

- Attach the front panel between the two corner supports using six M6 x 12 socket pan head bolts.
Note: Place the panel edges **INSIDE** the corner support surfaces.
Note: Front panel and rear panel are both stamped 'A'. Front panel has warning label.
- Repeat above step for the rear panel.

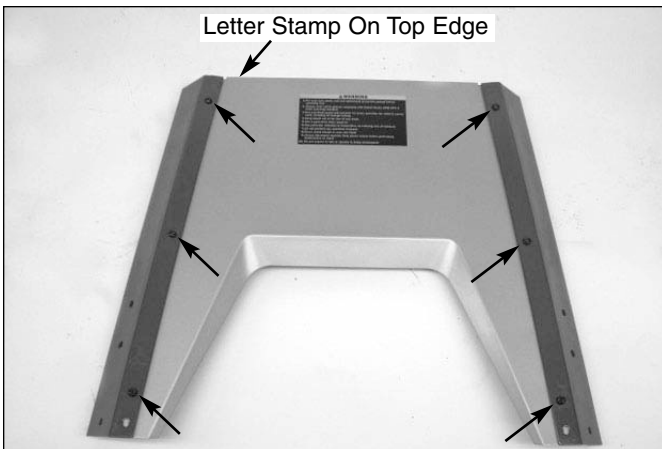

Figure 4

- Set both panel assemblies upside down on bench and attach the left side panel (stamped 'B') to the assemblies made above.
- Attach the right side panel (stamped 'C') to the assembly.

Below is completed base assembly.

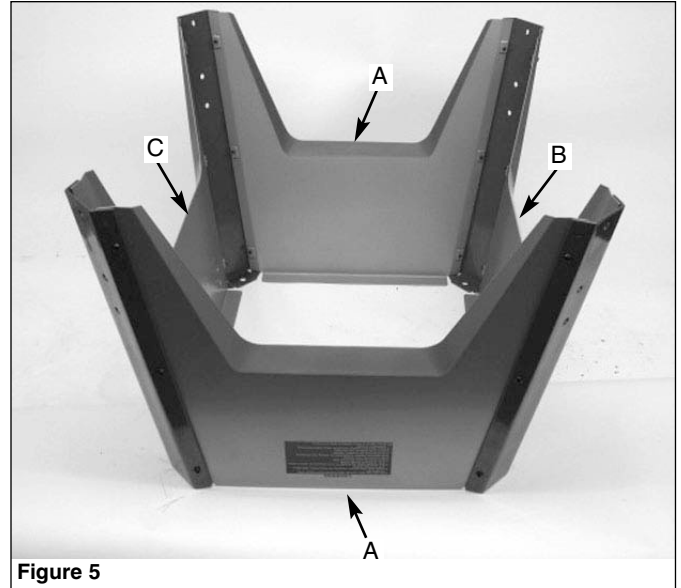

Figure 5

STEP 4

ASSEMBLE CASTER SETS

Tools Required: Two ½" Open End Wrenches

- Refer to Figure 6; remove casters (4) and supports (2) from carton.

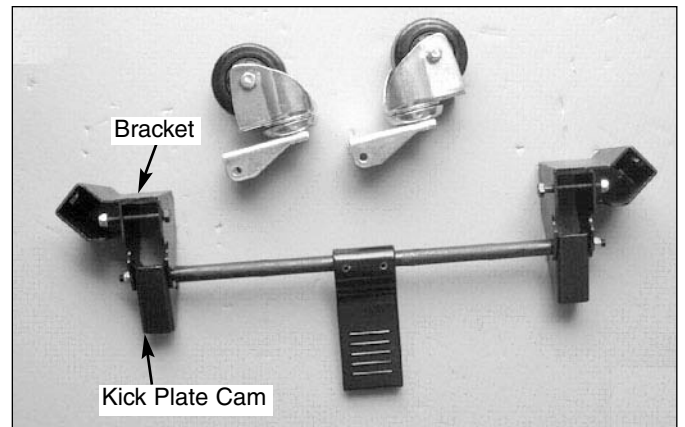

Figure 6

- Refer to Figure 7; loosen and remove the bolt and hex nut from the support. Rotate foot pedal bar so that kick plate cam is inside bracket. The kick plate cam must be underneath the caster to function properly.

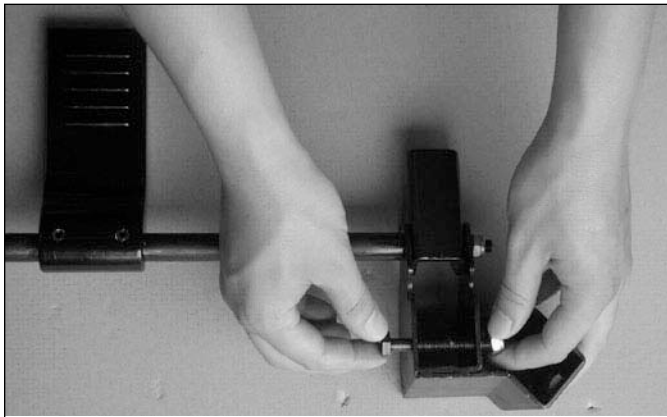

Figure 7

- Refer to Figure 8 and 9; place caster onto the support and secure in position with bolt and hex nut.

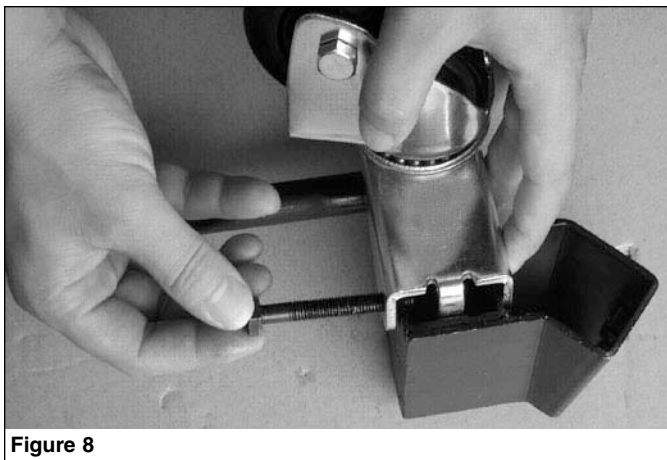

Figure 8

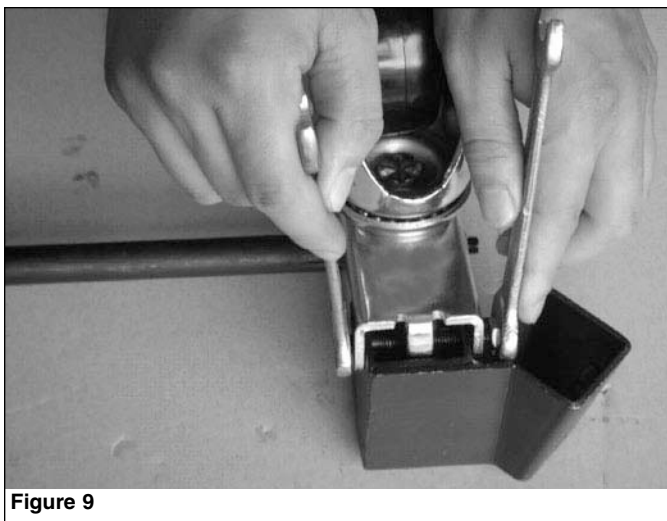

Figure 9

- Repeat above steps for the second caster set.

STEP 5

ATTACH CASTER SETS TO BASE

Tools Required: 5mm Hex Wrench

Hardware Required: Eight M8 x 16 socket pan head bolts (Hardware bag #4).

- Attach one caster set to the two front corner supports using four M8 x 16 socket pan head bolts.
- Attach the remaining caster set to the two rear corner supports.

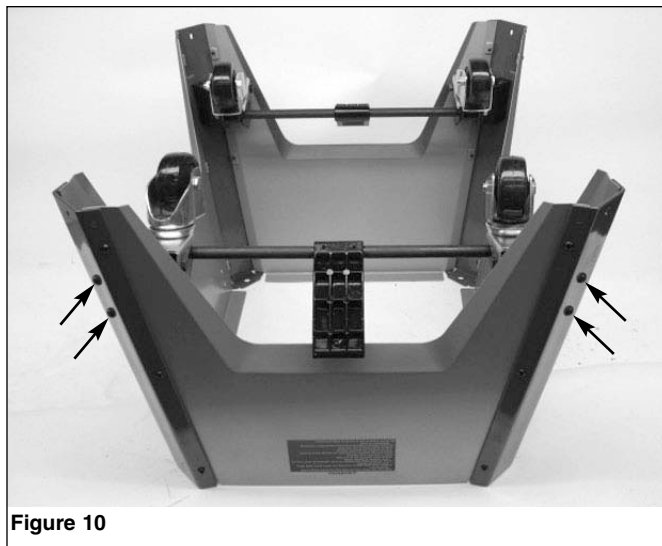

Figure 10

STEP 6

ATTACH LINE CORD HOOKS

Tools Required: 4mm Hex Wrench

Hardware Required: Two M6 x 16 socket pan head screws, two M6 flat washers and two M6 hex nuts (Hardware bag #4).

- Insert a screw into a line cord hook and place against the holes on the left side of the saw cabinet.
- Secure hook in position using flat washer and hex nut.
- Repeat for other hook.

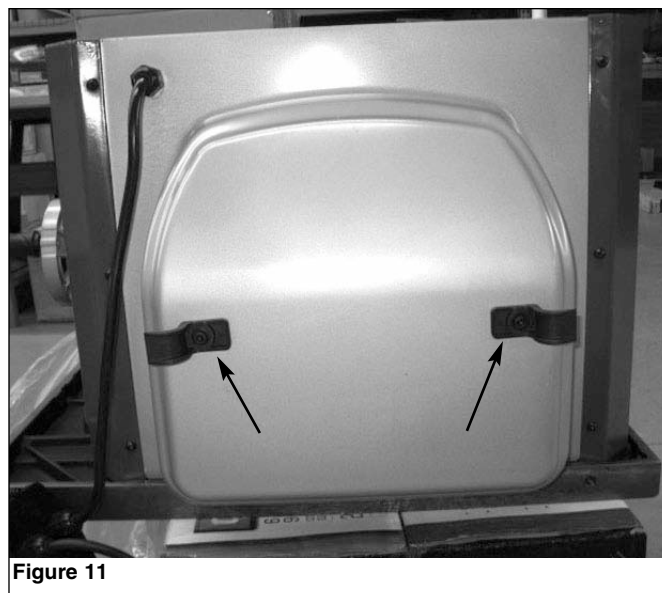

Figure 11

STEP 7

ATTACH BASE TO CABINET

Tools Required: 8mm Hex Wrench

Hardware Required: Four M10 x 25 socket head bolts, four M10 lock washers and four M10 flat washers (Hardware bag #4).

- Place dust chute over the cabinet as shown. Make sure the holes in the corners are aligned with the slots in the dust chute.



Figure 12

- Place the base assembly over the dust chute and secure the base assembly to the cabinet using the flat washers, lock washers and bolts.
- Secure all fasteners in the base assembly fully tight.

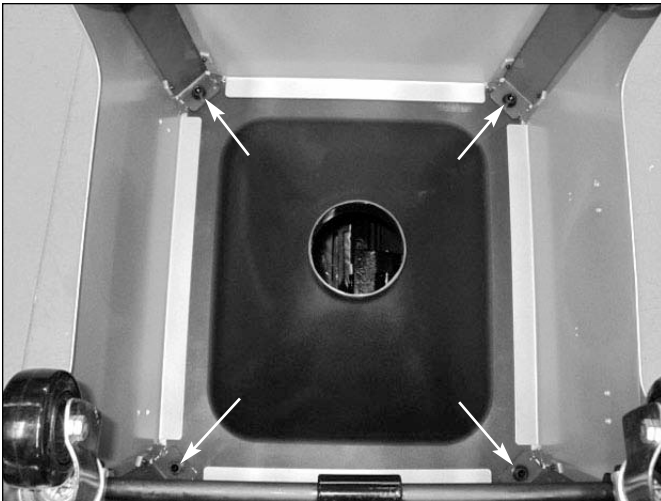

Figure 13

STEP 8

ATTACH RIP FENCE BRACKETS

Tools Required: 4mm Hex Wrench

Hardware Required: Two M6 x 16 socket head bolts, two M6 flat washers and two M6 hex nuts (Hardware bag #4).

Install the rip fence storage brackets to the right side panel of the base using two screws, flat washers and hex nuts.

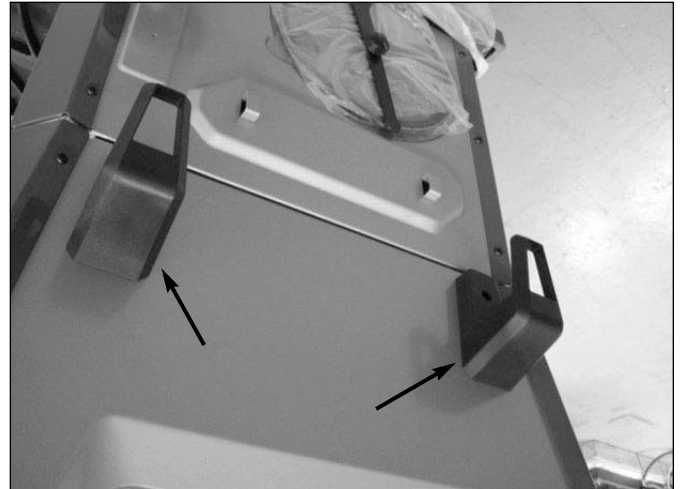

Figure 14

STEP 9

BLADE GUARD AND PUSH STICK STORAGE BRACKETS

Tools Required: Phillips screwdriver and 4mm hex wrench

Hardware Required: Four M3 x 10 pan head screws, four M3 lock washers, four M3 flat washers, four M5 x 12 socket head bolts, four M5 lock washers and four M5 flat washers (Hardware bag #4).

- Install the push stick storage brackets to the left side panel of the base using four screws, lock washers and flat washers.
- Install the blade guard storage brackets to the left side panel of the base using four screws, lock washers and flat washers.
- Press the four rubber feet to the base legs.
- Turn the saw upright.

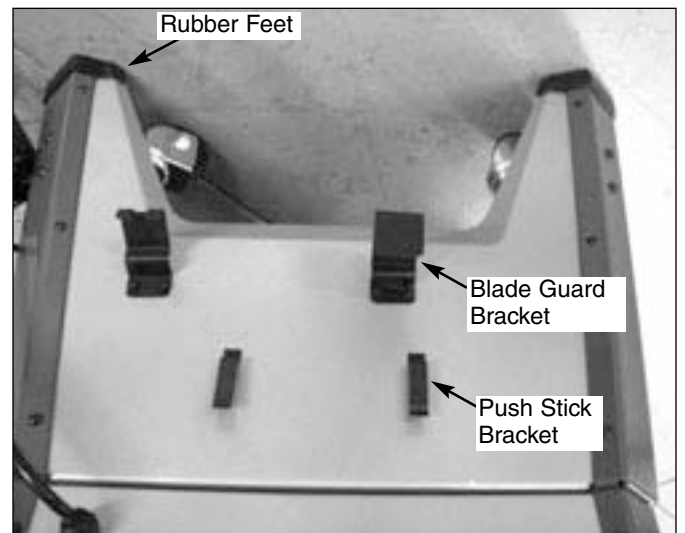

Figure 15

STEP 10

ATTACH EXTENSION TABLES

Tools Required: 13mm Open End Wrench and Straight Edge

Hardware Required: Six M10 x 25 hex head bolts, six M10 lock washers and six M10 flat washers (Hardware bag #1).

- Assemble extension table to the table using hex head bolts, lock washers and flat washers.
- Hand tighten only. Do not tighten completely until tables are level. Use a straightedge to level tables.
- Repeat above procedure for the other extension table.
- Use a straight edge to check level and flatness between main and extension tables.
- After tables are adjusted level and flat, secure the extension tables by tightening the hex nuts completely.

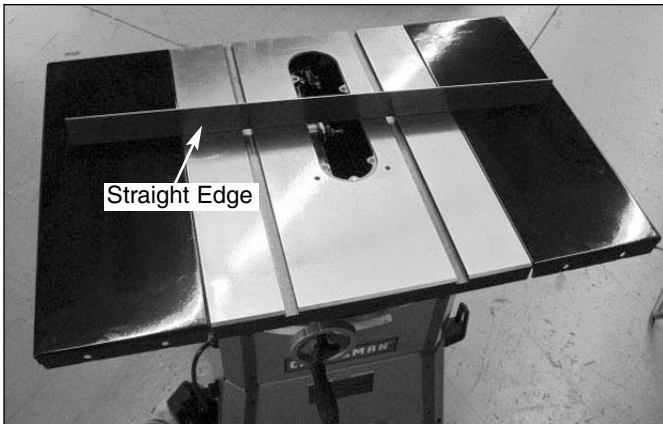

Figure 17

STEP 11

INSTALL BLADE

Tools Required: 13mm Open end Wrench

- Loosen knob on right side of cabinet.
- Remove blade and wrench. Replace knob.
- Depress arbor lock and use wrench to loosen flange nut. Remove flange and nut from arbor.

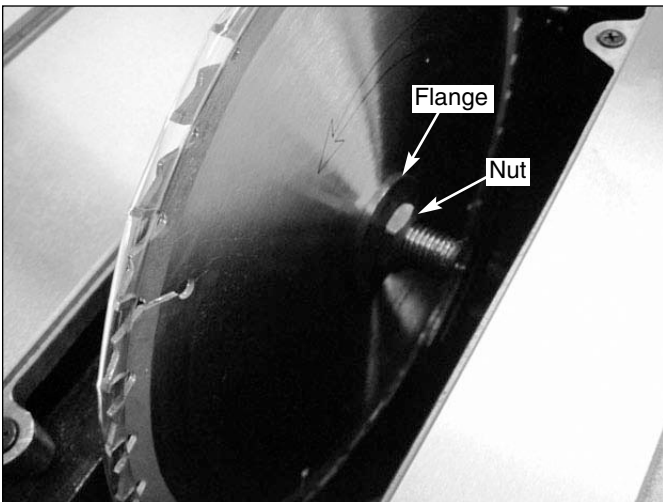

Figure 18

- Place blade on arbor. Make sure arrow on blade and teeth point towards front of saw.
- Replace flange and nut on arbor and securely snug blade in position.

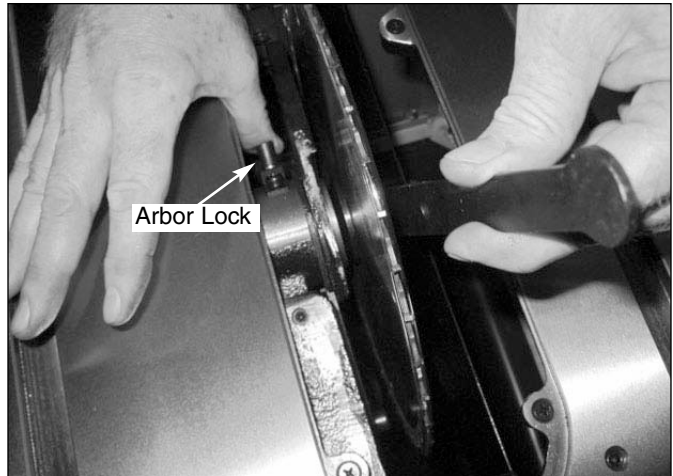

Figure 19

STEP 12

CHECK TABLE ALIGNMENT

- Saws are shipped from the factory with the table adjusted so the miter gauge slots are parallel to the saw blade. However, in order to obtain the best results from the saw, it is suggested this adjustment be checked before operating.
- A simple method of checking alignment is as follows: Bolt or clamp a dowel rod or similar object to miter gauge (a combination square can be substituted). Pick out a tooth on front of blade and set the dowel to it so it is just touching. Move same tooth to back of blade.
- Gauge this tooth with the dowel rod. If the tooth is in the same position, relative to the miter gauge slot, the table is parallel with the blade. In short, the miter gauge slots must be parallel with the blade. This means that when measuring distance between blade and slot at the front and rear of the blade, the distances will be equal (see Figure 20).

NOTE: Be positive to measure the distance or make the test on the same tooth of the saw blade in both front and rear positions.

- If an adjustment is necessary, proceed as follows: (Refer to Figure 13 in operator's manual). Loosen the hex head bolts and lock washers (Nos. 36, 37 and 38) of the trunnion. Shift trunnion until a position is found where the saw blade is parallel to the miter gauge slots.

NOTE: Saw blade should also be centered within its table insert opening.

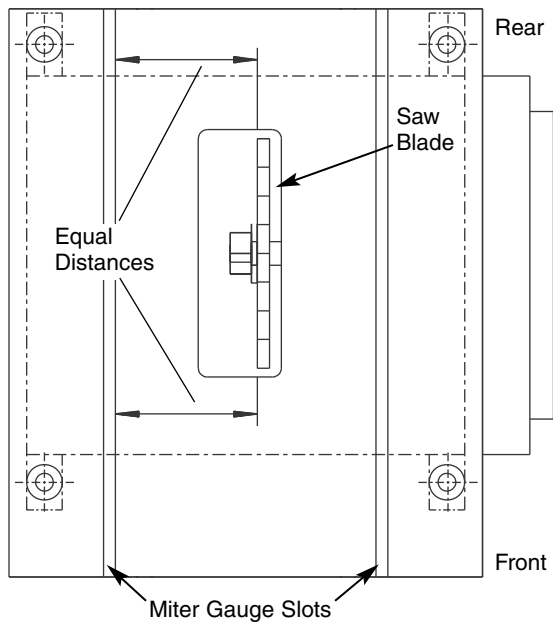

Figure 20 - Aligning Miter Slots to Blade

- Tighten the hex head bolts and lock washers very securely. This procedure will set the table and blade in parallel position and prevent the trunnion from shifting.

STEP 13

RAIL ASSEMBLY

Tools Required: 13mm Open end Wrench

Hardware Required: Eight M8 x 28 hex head bolts, eight M8 x 25 hex head bolts, four M8 x 20 hex head bolts, twenty M8 lock washers, twenty M8 flat washers, sixteen M8 hex nuts and four M8 acorn nuts. (Hardware bag #2).

- Insert two M8 x 28 hex head bolts and two M8 x 25 hex head bolts into the T-slot of the right front guide rail. (The two longer bolts will attach to the table; the two shorter bolts attach to the table extension.)
- Attach right front rail to the table and right table extension using flat washers, lock washers and hex nuts.

NOTE: Hand tighten all hardware during rail assembly. Do not completely tighten hardware until all rails are mounted.

- Attach left front rail in the same manner. (The two longer bolts attach to the table; the two shorter bolts attach to table extension.)

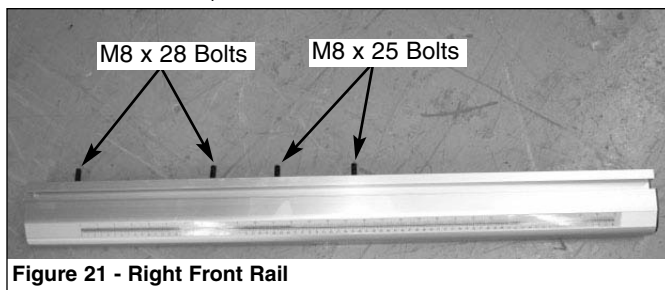

Figure 21 - Right Front Rail

- Position rails so that rails are butted together and the joint between rails is aligned with the blade. You may need a mallet to lightly tap rails together. Make sure rails are completely butted together at the joint.
- Use a straight edge to check level and flatness between right and left rail and make certain that both front rails are parallel to the table surface..

- After front rails are adjusted level and flat, tighten the screws completely.
- Secure all hardware completely.



Figure 22 - Use Straight Edge to Align Rail Joint to Blade

- Loosen and remove six socket pan head screws and the back panel. This will allow easier attachment of the rear rails.



Figure 23

- Install the rear rails in the same manner as the front rails and align the rail joint to the blade.
- Replace back panel of the cabinet.



Figure 24

- Attach brace to the far right end of the rails. Simultaneously slide brace with hex bolts into the rail T-slots and secure in position using lock washers, flat washers and acorn nuts.

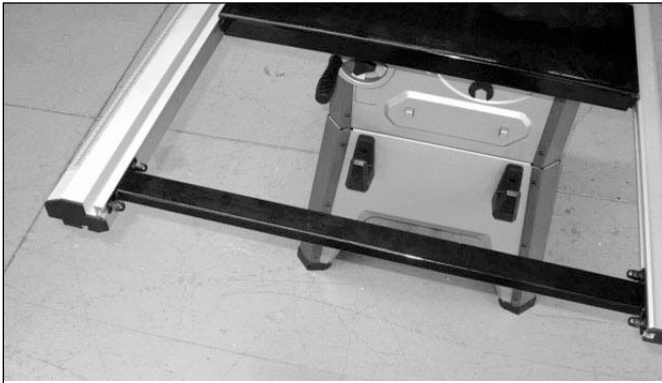

Figure 25

STEP 14

ATTACH SWITCH ASSEMBLY

Tools Required: 10mm Open end Wrench

Hardware Required: Two M6 x 16 hex head bolts, two M6 flat washers, two M6 lock washers and two M6 hex nuts. (Hardware bag #3).

- Insert the two M6 x 16 hex head bolts into the T-slot on the bottom of the left front rail. Position bolts approximately 6 to 8" from the left end of the rail.
- Attach switch assembly to bolts and secure in position with flat washers, lock washers and hex nuts.



Figure 26

STEP 15

POSITION AND ADJUST RIVING KNIFE

- Riving knife is installed on the saw. Raise the blade completely to access the riving knife.
- Loosen the locking knob and raise the riving knife to its highest position. Riving knife has three holes for three positions. The highest position is for all thru cuts. The middle position is for rabbets and other non-thru cuts, (with guard and pawls removed). The lowest position is for dado cuts.

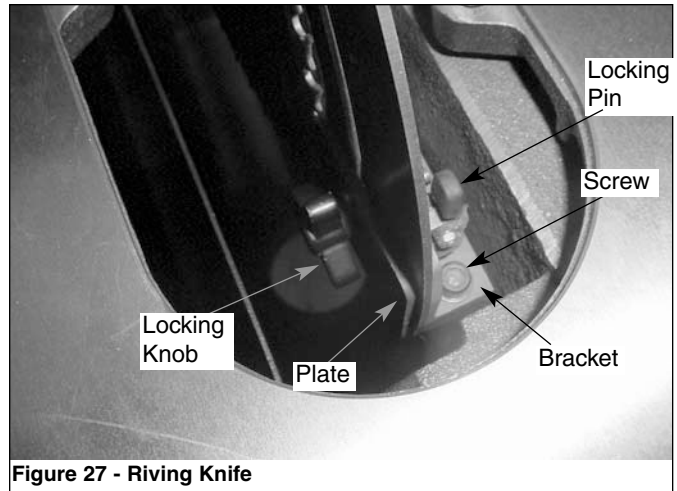

Figure 27 - Riving Knife

- Make sure locking pin is aligned with riving knife hole and secure in position by tightening locking knob.
- Riving knife must be in line with blade. Make sure riving knife sits flat against mounting bracket and lock plate.

RIVING KNIFE TO BLADE ADJUSTMENT

- Riving knife to blade clearance: the gap between the riving knife and the saw blade should be an even distance across the entire radius.
- The riving knife should also be in line with the saw blade. If adjustment is necessary:
 1. Locate the riving knife bracket.
 2. Loosen the two socket head cap screws slightly enough to move the bracket bringing the riving knife in line with the saw blade making sure the gap between the blade and knife is even and from $\frac{1}{4}$ to $\frac{5}{16}$ " in distance.
 3. Once the riving knife is aligned with the blade, tighten the socket head cap screws.

STEP 16

INSTALL TABLE INSERT

- Place table insert into throat of table.
- Insert is held in position by magnet in table.
- To adjust insert level with table, adjust leveling screws up or down.

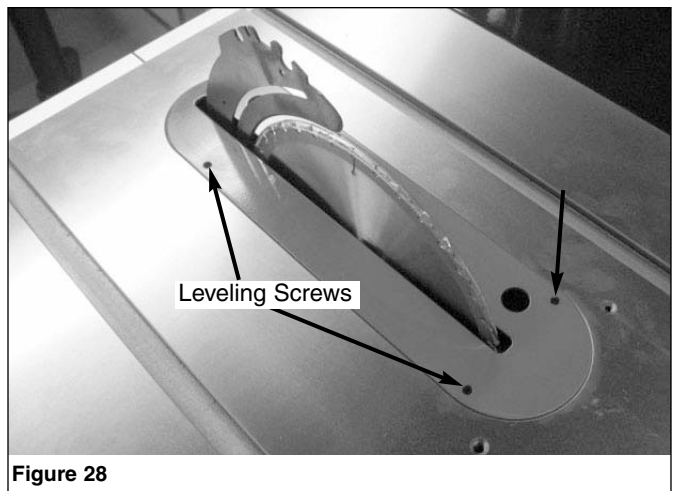

Figure 28

STEP 17

ATTACH BLADE GUARD AND ANTI-KICKBACK PAWLS

- Place the slot of blade guard body over the riving knife. Slot of bushing is placed in the notch indicated in Figures 29 and 30.
- The bushings have a beveled edge and must be located in the center of the slot to lock properly.
- Position guard completely down on riving knife and press latch to lock in position.
- Blade guard body should be parallel to the table. Use set screws to adjust if needed.
- Place anti-kickback pawl set onto riving knife at notches indicated. The spring pin is placed in the front notch and bolt is placed in the rear notch.
- Press pawl set completely down and press latch to secure in position.

NOTE: The teeth of anti-kickback pawls should touch table surface. Use set screws to adjust if needed.

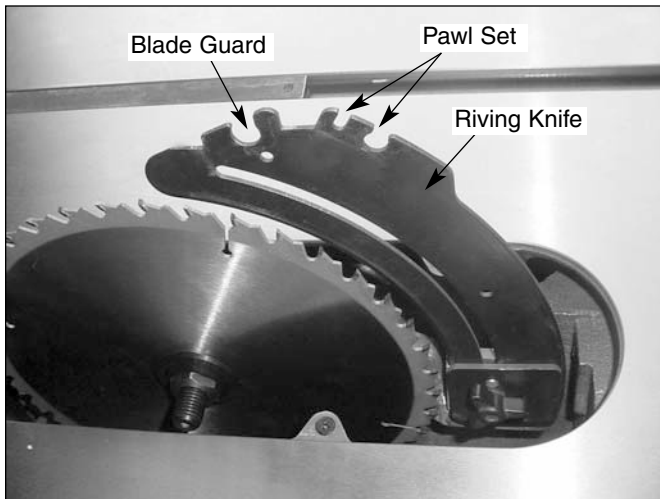

Figure 29 - Blade Guard and Pawl Attachment

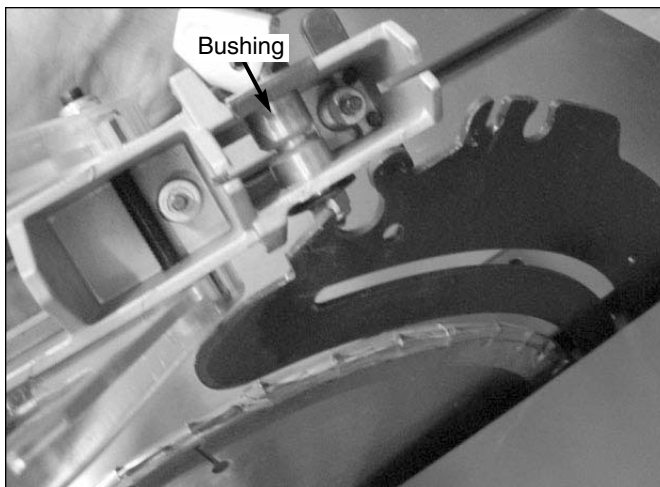

Figure 30

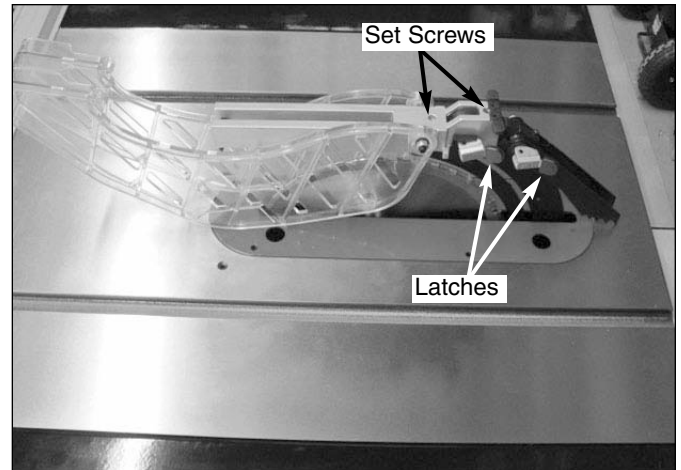

Figure 31 - Latches Lock and Unlock Blade Guard and Pawls to Riving Knife

STEP 18

INSTALL MITER GAUGE

- The miter gauge comes preassembled. Unpack the miter gauge and clean thoroughly. Insert into storage slots on right side of cabinet.

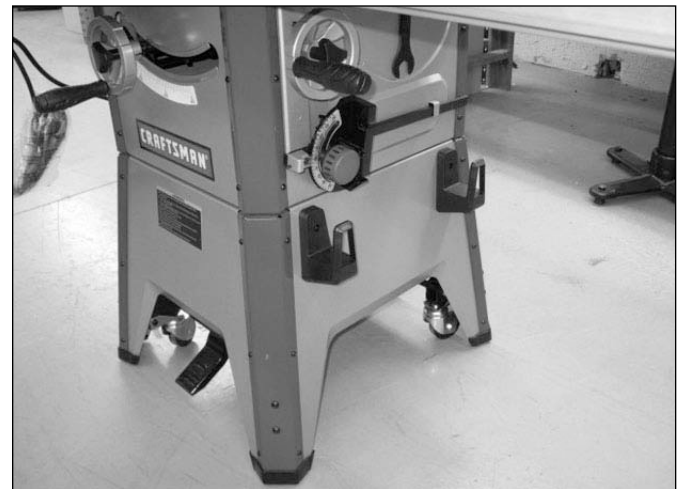

Figure 32

STEP 19

INSTALL PUSH STICK

- Insert the push stick into brackets on left side of base.



Figure 33

STEP 20

INSTALL RIP FENCE

- Position rip fence assembly at end of saw. Be certain locking lever is in UP unlocked position.
- Place rip fence assembly onto rails, positioning clamp over rear rail and then placing rip fence onto front guide rail.
- Rip fence should now ride freely on rip fence rails. Once rip fence is completely installed, it should be thoroughly adjusted.

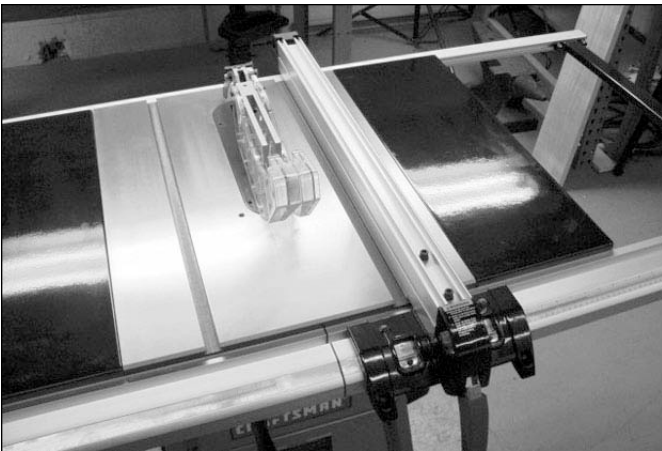

Figure 34

STEP 21

SAW COMPLETELY ASSEMBLED

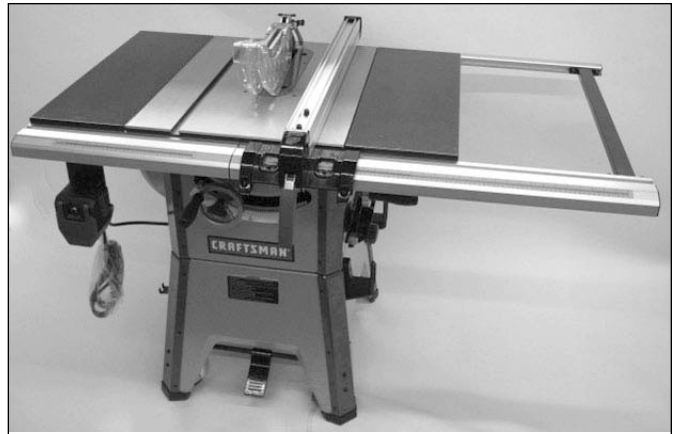

Figure 35

NOTES

Get it fixed, at your home or ours!

Your Home

For expert troubleshooting and home solutions advice:

manage my home

www.managemyhome.com

For repair – **in your home** – of **all** major brand appliances, lawn and garden equipment, or heating and cooling systems, **no matter who made it, no matter who sold it!**

For the replacement parts, accessories and owner's manuals that you need to do-it-yourself.

For Sears professional installation of home appliances and items like garage door openers and water heaters.

1-800-4-MY-HOME® (1-800-469-4663)

Call anytime, day or night (U.S.A. and Canada)

www.sears.com www.sears.ca

Our Home

For repair of carry-in items like vacuums, lawn equipment, and electronics, call anytime for the location of your nearest

Sears Parts & Repair Service Center

1-800-488-1222 (U.S.A.)

www.sears.com

1-800-469-4663 (Canada)

www.sears.ca

To purchase a protection agreement on a product serviced by Sears:

1-800-827-6655 (U.S.A.)

1-800-361-6665 (Canada)

Para pedir servicio de reparación a domicilio, y para ordenar piezas:

1-888-SU-HOGAR®

(1-888-784-6427)

Au Canada pour service en français:

1-800-LE-FOYER^{MC}

(1-800-533-6937)

www.sears.ca

Sears

© Registered Trademark / TM Trademark / SM Service Mark of Sears Brands, LLC

© Marca Registrada / TM Marca de Fábrica / SM Marca de Servicio de Sears Brands, LLC

^{MC} Marque de commerce / ^{MD} Marque déposée de Sears Brands, LLC

© Sears Brands, LLC